



**CITY OF OTHELLO**  
 BUILDING & PLANNING DEPARTMENT  
 500 E MAIN STREET, OTHELLO, WA99344  
 Building Dept. 509.488.3302 City Hall 509.488.5686  
 WWW.OTHELLOWA.GOV

Received By: \_\_\_\_\_

## BUILDING PERMIT APPLICATION

APPLICATION FOR:  COMMERCIAL  RESIDENTIAL  
 ADDITION/REMODEL  DEMOLITION  GARAGE/SHED  MECHANICAL  NEW  PATIO/PORCH  PLACEMENT  
 PLUMBING  ROOFING  SIGN (see page 2)  OTHER \_\_\_\_\_

### PROJECT SITE INFORMATION

Job Site Address: \_\_\_\_\_ Parcel #: \_\_\_\_\_

Legal Description (Lot#/Block#/Plat): \_\_\_\_\_

Description of work to be done: \_\_\_\_\_

\_\_\_\_\_

\_\_\_\_\_

Labor & Material Valuation: \$ \_\_\_\_\_ Dimensions: \_\_\_\_\_ ft X \_\_\_\_\_ ft = \_\_\_\_\_ Total SF

(Only applies to Garage/Shed/New home/commercial construction)

#### IF APPLICABLE

Will you need new water services:  Yes, When \_\_\_\_\_  No **OR** Will you connect to existing?  Yes  No

Will you need new sewer services:  Yes, When \_\_\_\_\_  No **OR** Will you connect to existing?  Yes  No

### APPLICANT INFORMATION

### OWNER INFORMATION

Name: \_\_\_\_\_

Name: \_\_\_\_\_

Mailing Address: \_\_\_\_\_

Mailing Address: \_\_\_\_\_

City/State/Zip: \_\_\_\_\_

City/State/Zip: \_\_\_\_\_

Phone Number: \_\_\_\_\_

Phone Number: \_\_\_\_\_

Email: \_\_\_\_\_

Email: \_\_\_\_\_

### CONTRACTOR INFORMATION

Name: \_\_\_\_\_ Phone Number: \_\_\_\_\_

Mailing Address: \_\_\_\_\_

City/State/Zip: \_\_\_\_\_

City Business License #: \_\_\_\_\_ WA State Contractor License #: \_\_\_\_\_

Email: \_\_\_\_\_

#### \*LIST ADDITIONAL CONTRACTORS\*

NAME:

PHONE:

1. \_\_\_\_\_

2. \_\_\_\_\_

3. \_\_\_\_\_

4. \_\_\_\_\_

**NOTE: ALL CONTRACTORS & SUBCONTRACTORS ARE REQUIRED TO HAVE AN OTHELLO BUSINESS LICENSE.**

**SIGN PERMIT (only):**     New                       Replace Existing

Sign # 1	Sign # 2	Sign # 3	Sign # 4
Internal or External Illumination Yes/No :	Internal or External Illumination Yes/No :	Internal or External Illumination Yes/No :	Internal or External Illumination Yes/No :
Type of Sign:	Type of Sign:	Type of Sign:	Type of Sign:
Sign Height (ft):	Sign Height (ft):	Sign Height (ft):	Sign Height (ft):
Sign Width (ft):	Sign Width (ft):	Sign Width (ft):	Sign Width (ft):
Wall Area (Façade-Width & Height):	Wall Area (Façade-Width & Height):	Wall Area (Façade-Width & Height):	Wall Area (Façade-Width & Height):

The applicant, his agents and employees shall comply with all the rules, restrictions and requirements of the Municipality and Building Codes governing location, construction and erection of the above proposed work for which the permit is granted. The Municipality or its agents are authorized to order the immediate cessation of construction at any time a violation of the codes or regulations appears to have occurred. Violation of any of the codes or regulations applicable may result in the revocation of this permit.

Buildings **MUST** conform with the plans, as submitted to the Municipality. Any changes of plans or layout must be approved prior to the changes being made. Any changes in the use or occupancy of the building or structure must be approved prior to proceeding with construction.

The applicant is required to call for inspections at various stages of the construction, and in accordance with the aforesaid rule, the applicant shall give the building inspector not less than one day's notice to perform such activities. The permit is automatically void in the event construction is not commenced within 180 days of issuance of this point. Cessation of work for a period of 180 continuous days shall also cause this permit to be void. Permits are not transferable.

I hereby certify that as a contractor I am currently registered and properly licensed as defined in RCW 18.27 OR as property owner/authorized agent, I am exempt from the requirements of the contractor registration and will do all my own work or use properly licensed subcontractors in connection with the work to be performed under this permit. I further certify that I have read and examined this application and know the same to be true and correct. If any of the information provided is incorrect, the permit may be revoked.

\_\_\_\_\_  
Signature of Owner/Authorized Agent

\_\_\_\_\_  
Date

\_\_\_\_\_  
Print Name

**\*PLEASE REVIEW FOR COMPLETENESS PRIOR TO SUBMITAL\***



# Building Guide

## Single Family Residential Patio Covers & Carports

### How to Use this Guide

Check with your jurisdiction regarding type of submittal (paper or electronic) and for additional requirements. Draw to scale and complete the following (hint: use graph paper with  $\frac{1}{4}$ " squares. Example:  $\frac{1}{4}$ " = 1').

**1 Complete this Building Guide** by filling in the blanks on page two, and indicating which construction details will be used.

**2 Provide 2 Plot Plans** (site plan) showing dimensions of your project or addition and its relationship to existing buildings or structures on the property and the distance to existing property lines drawn to scale. See Page 2

**3 Fill out a building permit application.**

The majority of permit applications are processed with little delay. The submitted documents will help determine if the project is in compliance with building safety codes, zoning ordinances and other applicable laws.

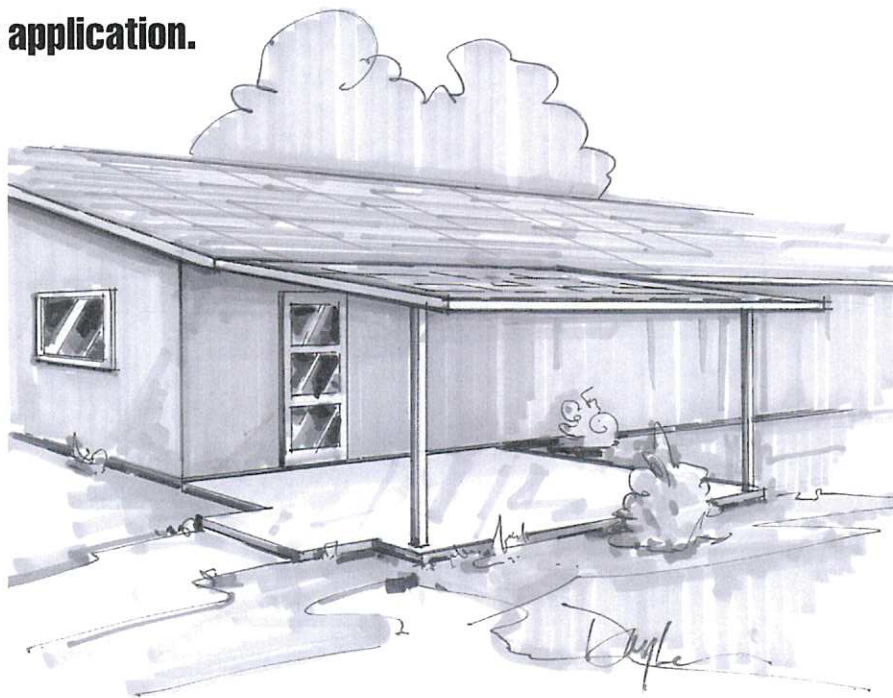



# Single Family Residential Patio Covers & Carports

## Site Plan Example

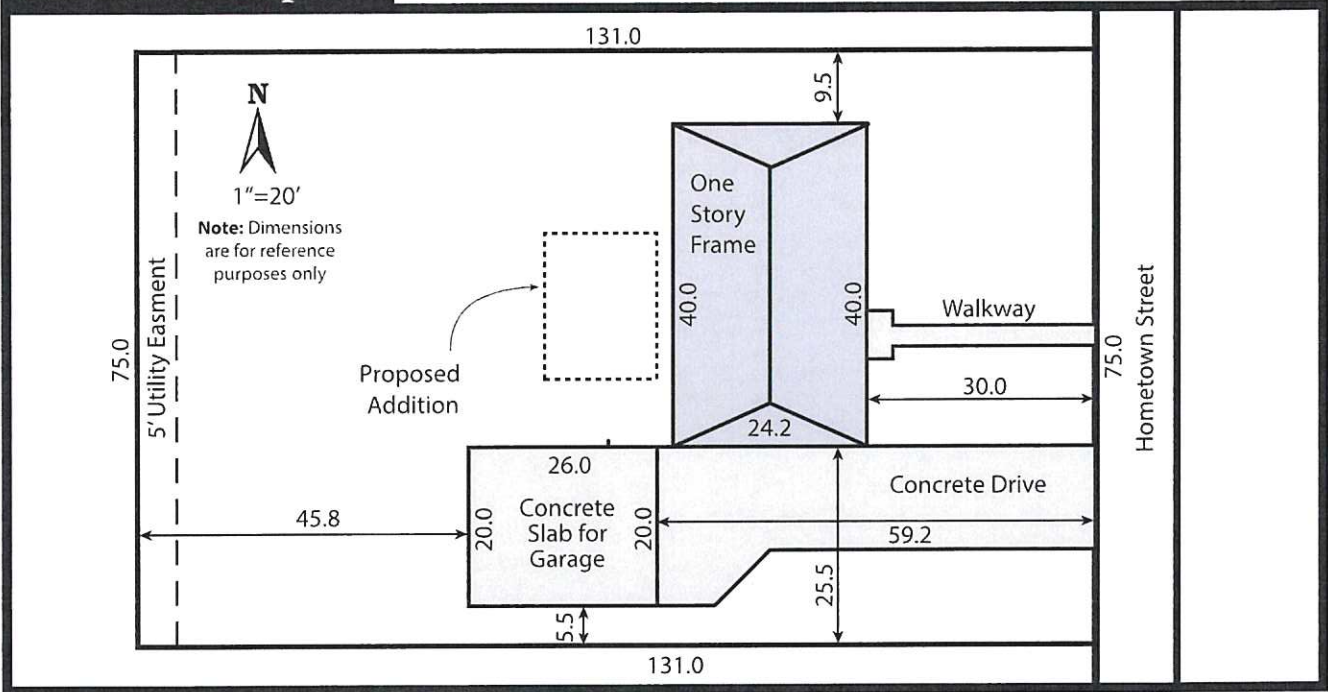

Note: Manufactured homes require independent/self supported patio structure



# Single Family Residential Patio Covers & Carports

## Directions

Address: \_\_\_\_\_

1. Fill in the blanks with dimensions and materials which will be used to build the structure. Please print legibly.
2. Indicate in the check boxes which details from page 4 will be used. Please note if any of the sides of your carport addition are closer than 5'-0" to the property line, that side of the carport must be enclosed with a solid 1 hour fire rated wall as shown in Alternate Details B and C. You must however, keep at least two sides of the carport open to conform to the building code requirements. Zoning approval is required.
3. Roofing to be installed per manufacturer's instructions, including low slope application and required inspections made.

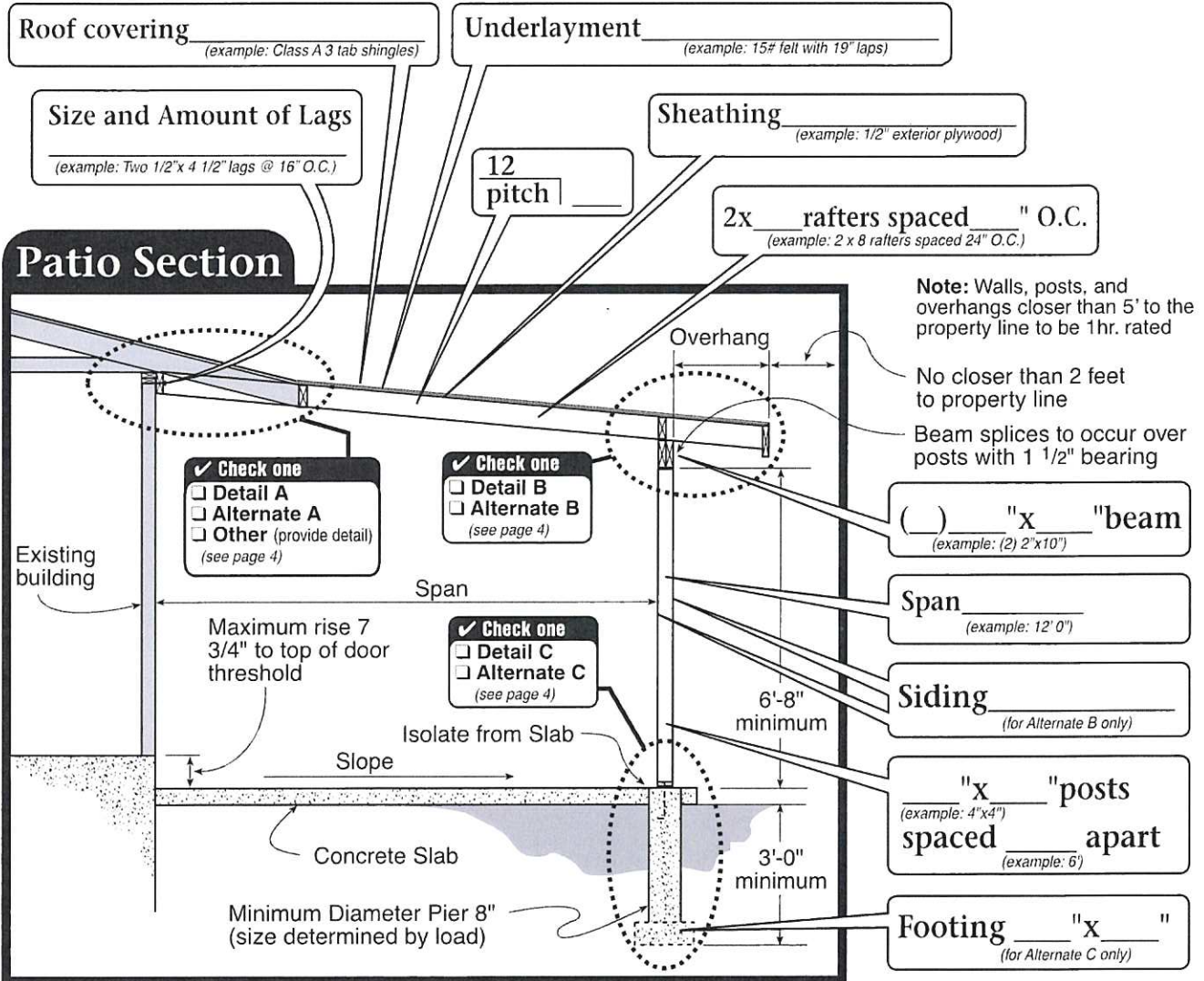





# Single Family Residential Patio Covers & Carports

**Detail A**

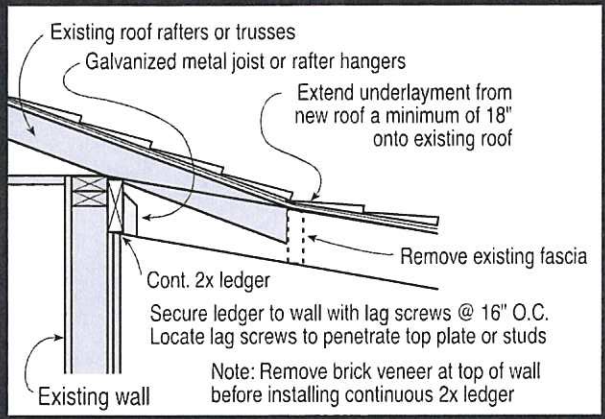

**Alternate Detail A**

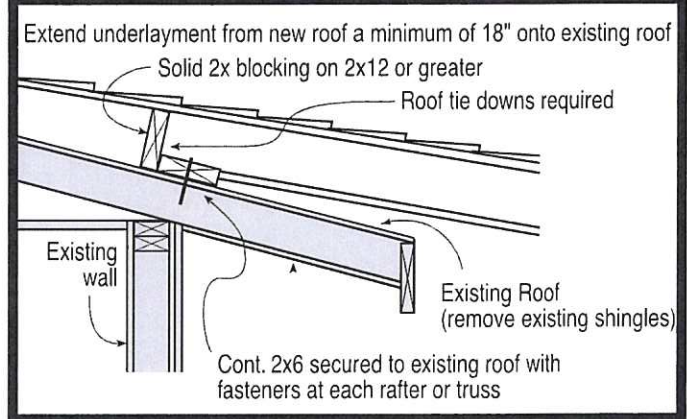

**Detail B**

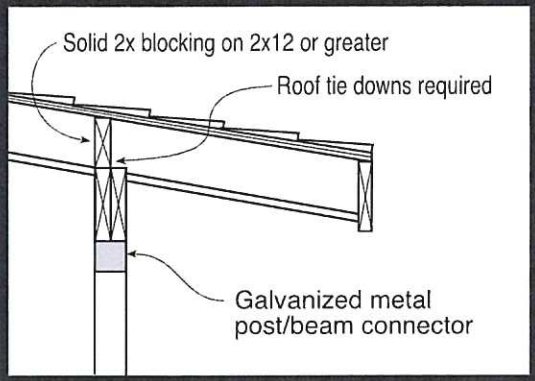

**Alternate Detail B - 1 Hour Wall**

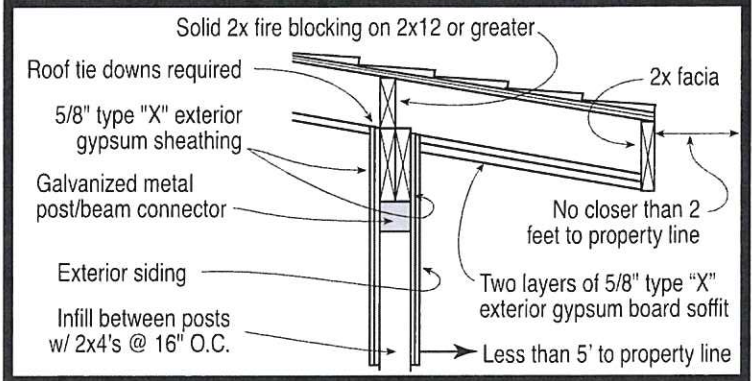

**Detail C**

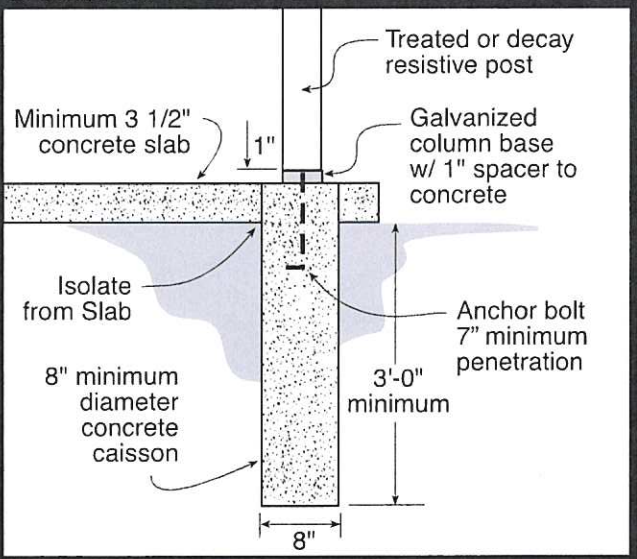

**Alternate Detail C - 1 Hour Wall**

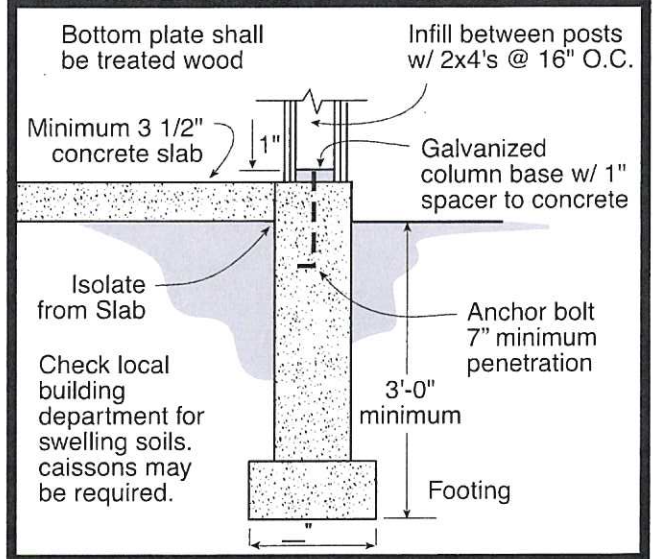



# SITE PLAN

Site Address: \_\_\_\_\_ Indicate Scale: Each Unit = \_\_\_\_\_ feet

